



Change description	Date	Designed by
--------------------	------	-------------

MAIN DIMENSIONS

DETAIL A
SCALE 2 : 1

MONO EDGE

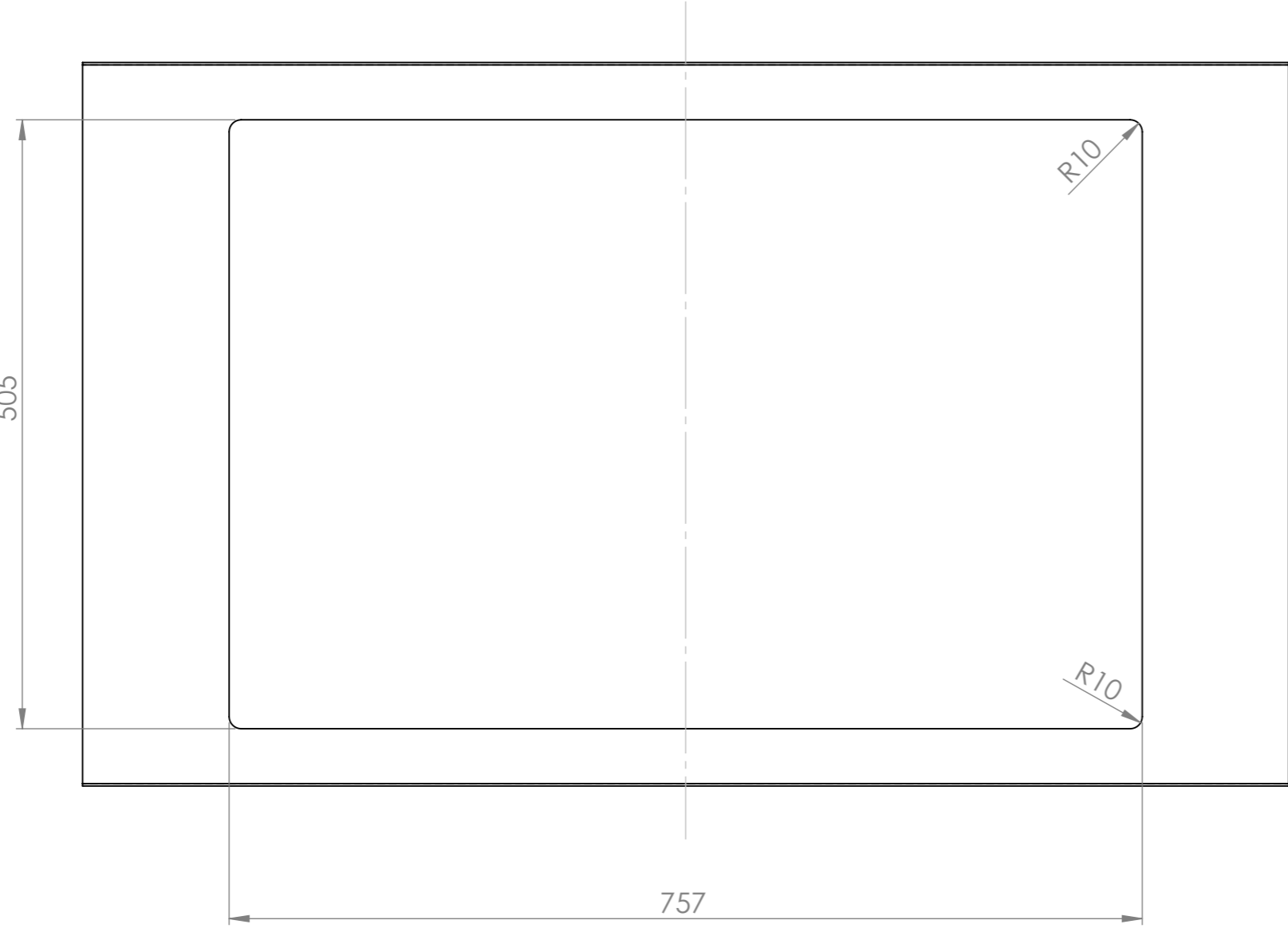
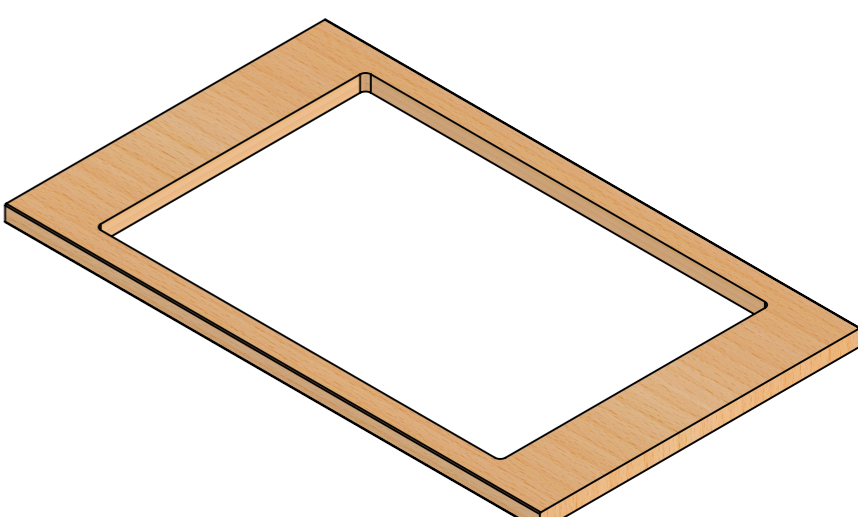
	Mass	kg	General tolerance	Designed by	Date
	Size	Scale	Item	VS	04.12.2025
 STALA Member of ALVEUS	A3	1:5	Description	Approved by	Date
			ONE-T70	SV	13.02.2026
			Technical Data Sheet	Drawing number	Sheet/sheets
			20049	1/3	Rev
				A	

1	2	3	4	5	6	7	8	
				Change description	Date	Designed by		
A	CUT-OUT							A
B								B
C								C
D								D
E								E
F	 Member of ALVEUS				 Mass kg Size Scale A3 1:5	General tolerance Item Description ONE-T70 Technical Data Sheet	Designed by VS Approved by SV Drawing number 20049	Date 04.12.2025 Date 13.02.2026 Sheet/sheets 2/3 Rev A
1	2	3	4	5	6	7	8	

Change description	Date	Designed by
--------------------	------	-------------

SPACE REQUIREMENTS

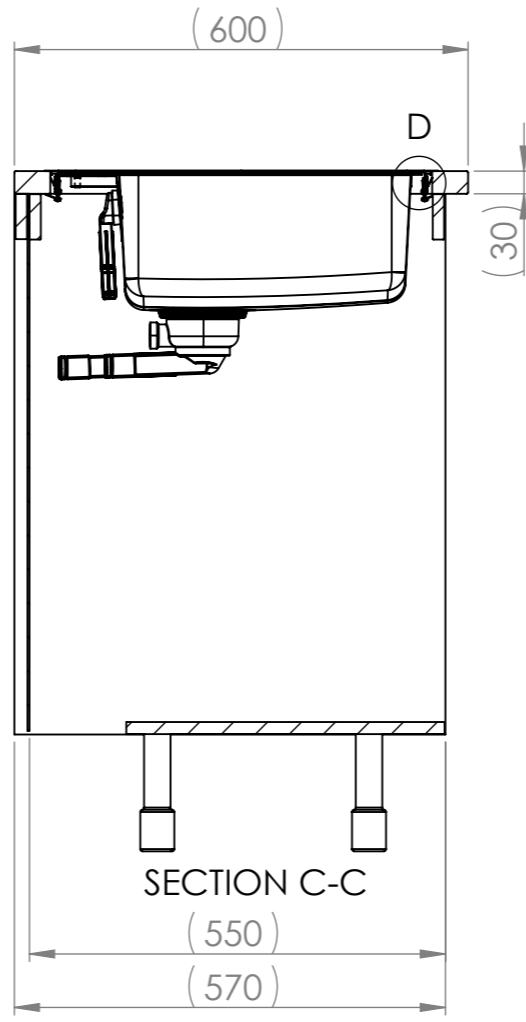
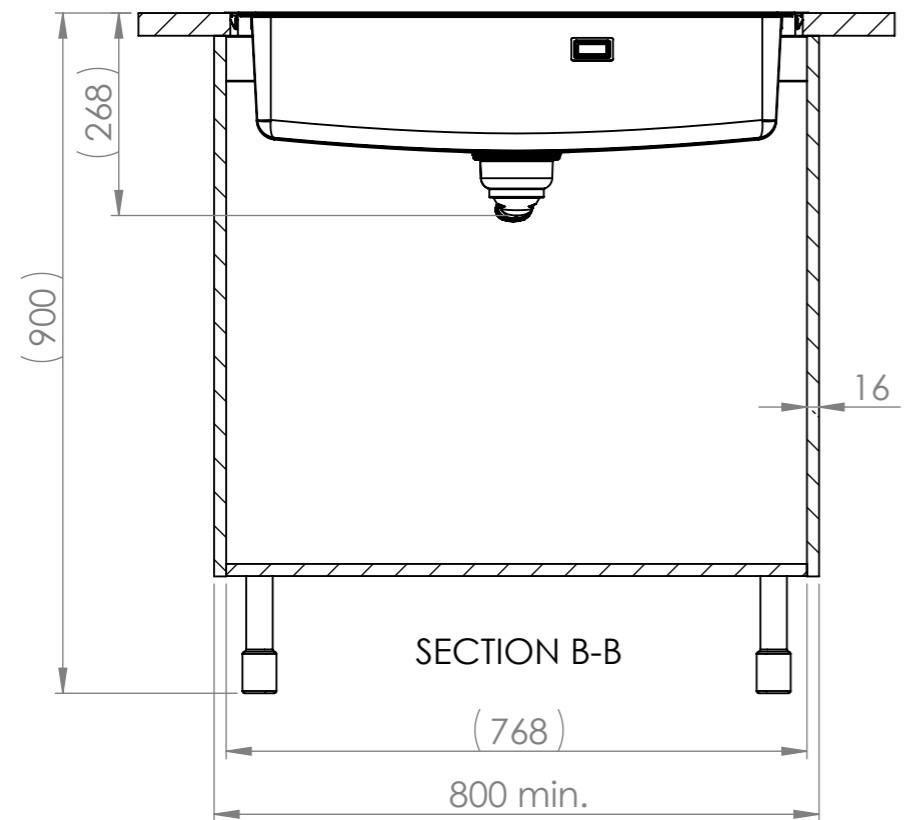

DETAIL D
SCALE 1 : 1

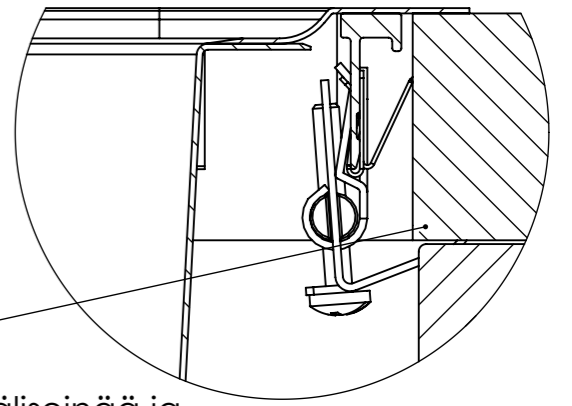

Huom!
Tarvittaessa kaapin väliseinää ja etu/takalistaa lovetettava kiinnikkeitä varten ja pesuallas on kiinnitettävä ennen työtason asennusta.
Obs!
Vid behov måste en inskärning för hofästena göras i skåpets mellanvägg och förbindningslist och diskbänken måste fästas innan du monterar bänkskivan.
Notice!
The partition walls and front/back list of E the cupboard must be notched for the sink mountings when needed and the sink must be fastened before installing the worktop.

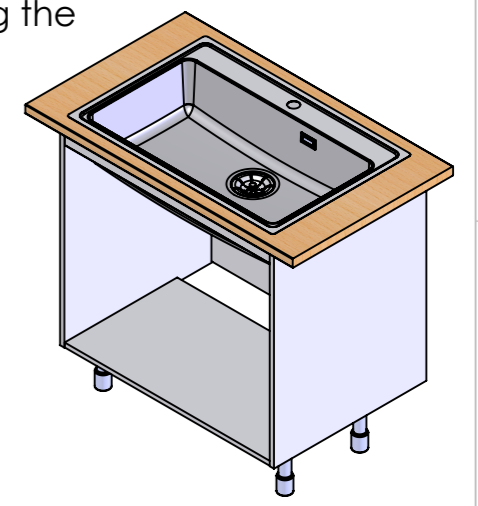
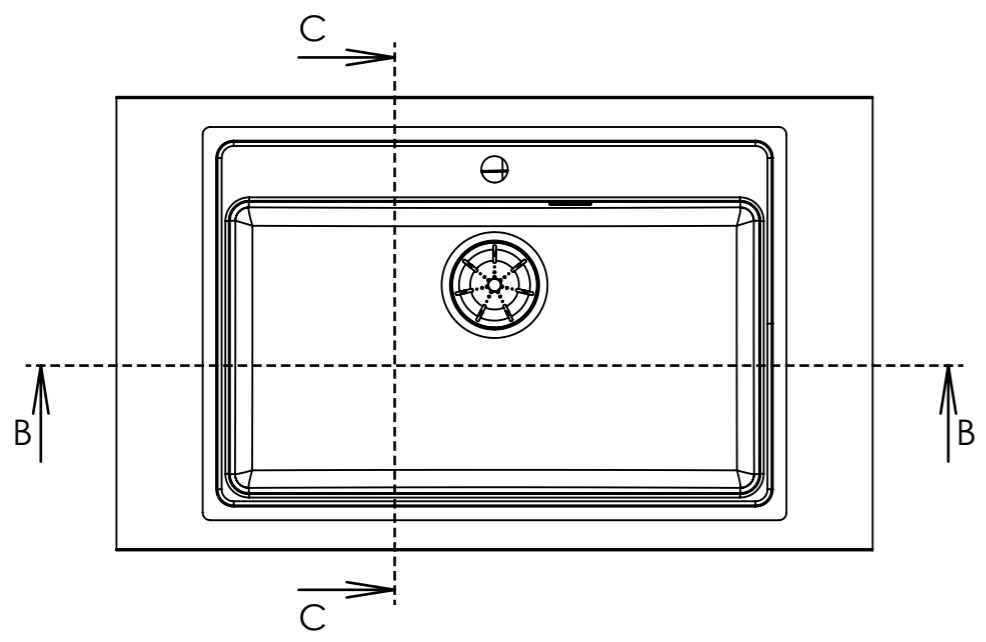

	Mass	kg	General tolerance	Designed by	Date
	Size	Scale		Item	VS
	A3	1:10	Description	Approved by	Date
	STALA Member of ALVEUS		ONE-T70	SV	13.02.2026
	Technical Data Sheet		Drawing number 20049	Sheet/sheets 3/3	Rev A